

SAFETY RECALL BULLETIN

SUBJECT: TRANSFER CASE LEAKAGE — SAFETY RECALL CAMPAIGN		No: SR-02-003	
		DATE: December, 2002	
		MODEL: 1991-99 3000GT VR-4	
CIRCULATE TO:	<input type="checkbox"/> GENERAL MANAGER	<input checked="" type="checkbox"/> PARTS MANAGER	<input checked="" type="checkbox"/> TECHNICIAN
<input checked="" type="checkbox"/> SERVICE ADVISOR	<input checked="" type="checkbox"/> SERVICE MANAGER	<input checked="" type="checkbox"/> WARRANTY PROCESSOR	<input type="checkbox"/> SALES MANAGER

PURPOSE

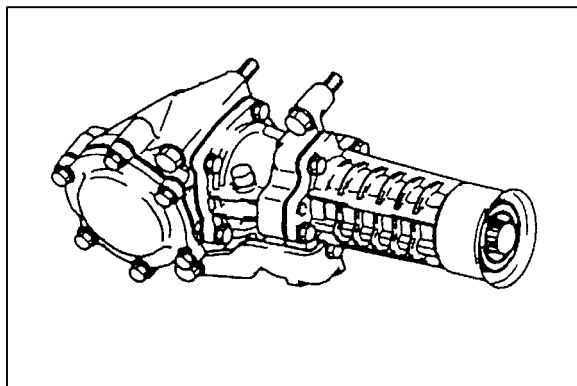

This bulletin is to inform Mitsubishi Motors dealers of a safety recall on some 1991 – 1999 3000GT VR-4 vehicles. This safety recall involves leakage of transfer case oil and possible subsequent damage and failure of the transfer case. Transfer case failure could cause the vehicle's drive wheels to lock up and possibly result in a loss of vehicle control.

Mitsubishi Motors has developed recall procedures for repairing these vehicles, which are included in this bulletin.

AFFECTED VEHICLES

1991-1999 3000GT VR-4

CUSTOMER NOTIFICATION

A letter will be sent to all owners of affected vehicles instructing them to bring their vehicle to their Mitsubishi Motors dealer to have the transfer case inspected for leakage and damage and repaired as necessary. A copy of the customer notification letter appears later in this bulletin.

REQUIRED OPERATIONS

Before starting the PROCEDURE section of this bulletin, **CHECK ON THE WARRANTY SUPERSCREEN** to verify that the vehicle is an affected VIN for this campaign and that this campaign procedure has not already been completed.

NOTE:

Some of the affected vehicles may be in your dealership's used vehicle inventory. This recall campaign should be performed on these vehicles before retail delivery. This recall should also be performed on any affected vehicle that might be in for service.

REPAIR SUMMARY

Inspect the transfer case for leakage. If it is not leaking, change the transfer case fluid. If there is leakage, re-seal the transfer case with the Repair Kit as instructed in this bulletin. If the transfer case is cracked or if there is internal gear damage, replace the transfer case. (Refer to the PARTS INFORMATION section of this bulletin for details regarding ordering a new transfer case.)

Continued

FILE UNDER:	Safety Recall Bulletins in the Dealer Service Information Binder	(2482)
--------------------	---	---------------

PROCEDURES

A. Inspect Transfer Case

1. Raise the vehicle in a lift or hoist.

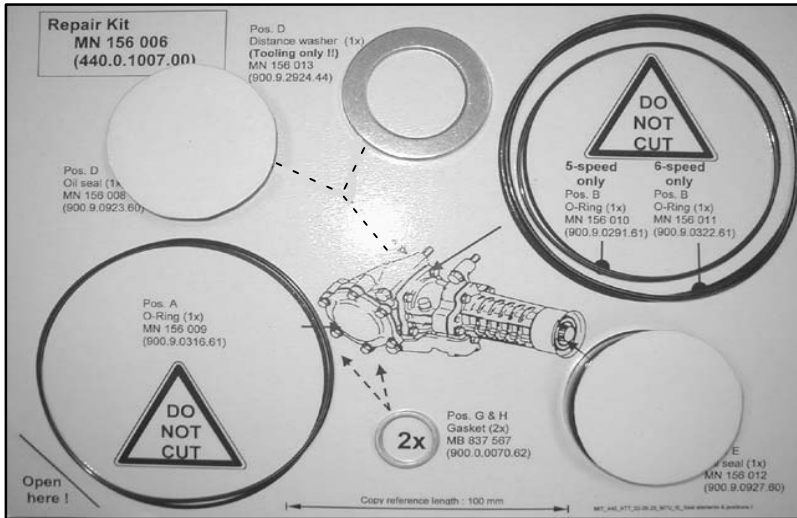

REPAIR KIT
P/N MN156006

2. Inspect the transfer case for evidence of oil leakage in the areas indicated. If there is **NO LEAKAGE**, change the transfer case oil and return the vehicle to the customer as instructed in [Step 3](#), below.

If there is visible oil leakage, go to [Step 4](#) for transfer case inspection. Inspect the visible leaks thoroughly and record information concerning the leaks on the Transfer Case Leakage Dealer Check Form, which is on the last page of this bulletin. Make a copy of this form. Keep this form for your records if you are re-sealing the transfer case. Send in a copy of this form with the old transfer case if you are replacing the transfer case because of damage, wear, or binding.

3. DRAIN AND REFILL THE TRANSFER CASE

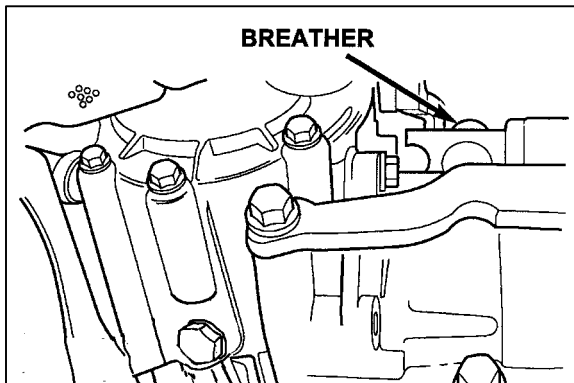

- a. Remove the transfer case breather.

Continued

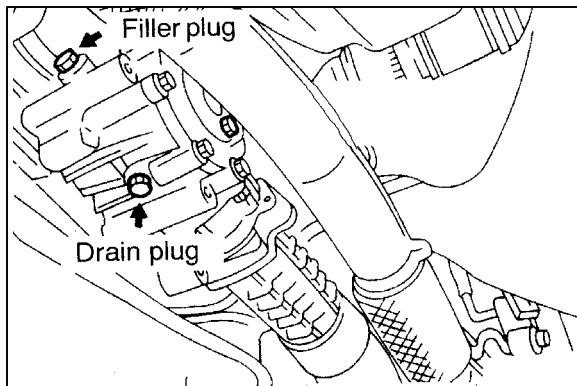

- b. Remove the transfer case filler plug
- c. Remove the transfer case drain plug and drain the oil. Measure the quantity of oil removed and record it for your records on the repair order.
- d. Clean and reinstall the drain plug. Tighten to the standard torque value: **300 in-lbs (35 Nm)**
- e. Using genuine Mitsubishi Diamond Gear Lube 75W-90/GL-5 (A991ZC2X01), refill the transfer case with the quantity indicated below:
5-speed M/T = 8.5 oz. (250cc)
6-speed M/T = 18.5 oz. (550cc)

NOTE:

A small amount of oil will remain in the transfer case after draining, therefore, use the exact quantities listed above when refilling the transfer case.

CAUTION

DO NOT overfill the transfer case. Make sure the transfer case is filled to the correct quantity as shown above. Overfilling the transfer case can cause powertrain damage.

- f. Clean and reinstall the filler plug. Tighten to the standard torque value: **300 in-lbs (35 Nm)**
- g. Clean the transfer case breather and seat. Apply Mitsubishi Weatherstrip Adhesive (A990ZC1X03) around the breather hole and install the breather.
- h. Lower the vehicle from the lift/hoist.
- i. Test drive the vehicle and inspect for leakage.
- j. Return the vehicle to the customer. No further action is required.

TRANSFER CASE REMOVAL

4. Inspect the transfer case for signs of any cracks or breaks. If cracks or breaks are identified, remove the transfer case using Steps 5 through 13 below, then proceed with **Section C. – Installing Transfer Case.**

NOTE:

Transfer case replacement requires approval from Tech Line. Be sure to contact Tech Line before ordering a new transfer case.

5. Remove the transfer case filler plug.
6. Remove the transfer case drain plug and drain the fluid from the transfer case. See illustration in Step 2-c. Measure the amount of oil which drains from the transfer case and record it on the Transfer Case Leak Dealer Check Form.

Continued

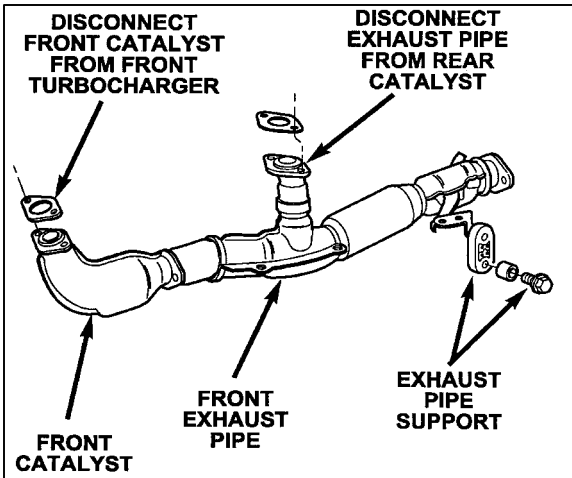

7. Remove the two nuts that secure the exhaust pipe to the rear turbocharger-mounted catalytic converter. Discard the nuts.
8. Remove the two nuts that secure the front catalytic converter to the front turbocharger outlet. Discard the nuts.
9. Disconnect the front exhaust pipe support. Disconnect the front exhaust pipe and temporarily support the front exhaust pipe with a wire or bungee cord.
10. Remove and discard the 2 exhaust gaskets.

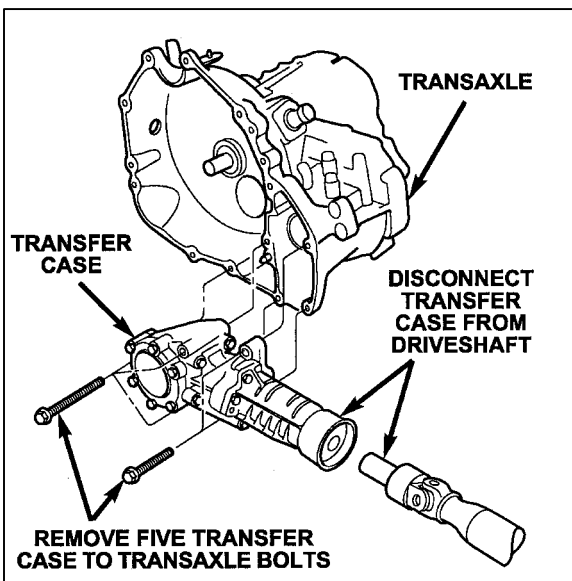

11. Remove the 5 bolts that secure the transfer case to the transaxle.
NOTE:
The upper mounting bolt may be hidden from view.
12. Separate the transfer case from the transaxle. It may be necessary to tap the transfer case with a plastic hammer to loosen it.
13. Tilt the transfer case downward then remove the transfer case from the transaxle. Disconnect the transfer case from the driveshaft and set it on a clean work surface.

⚠ CAUTION

DO NOT let the driveshaft hang. The universal joint can be damaged if the driveshaft could bend. Support the driveshaft with a wire or bungee cord.

TRANSFER CASE INSPECTION

14. Remove and discard the aluminum gaskets from the transfer case filler and drain plugs. Clean the filler and drain plugs. Set them aside for use later.

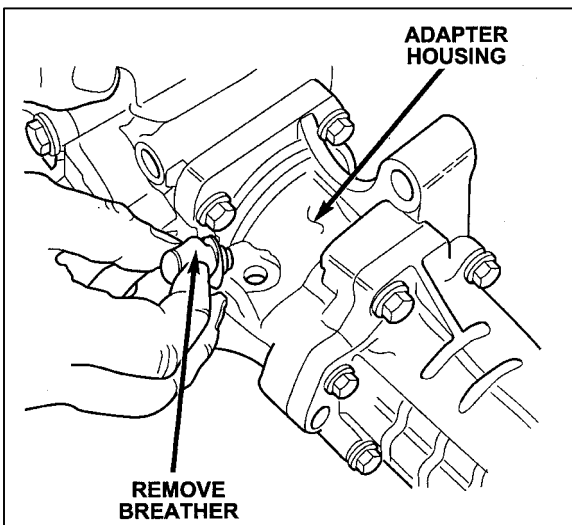

15. Remove the transfer case breather. Clean the breather and set it aside for re-use later.

Continued

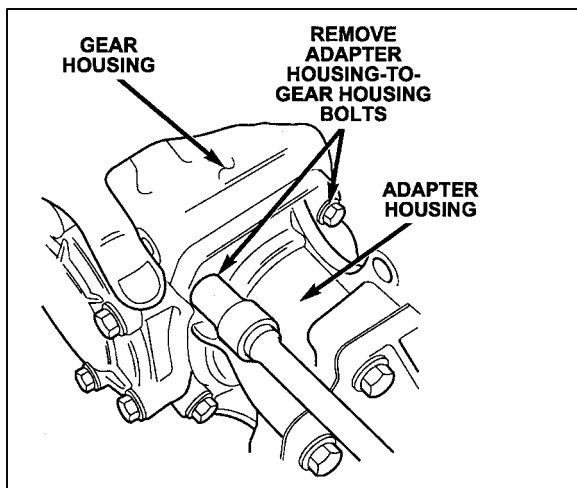

16. Remove the bolts that secure the transfer case gear housing to the adapter housing.

NOTE:

There are five (5) bolts on 5-speed equipped vehicles and seven (7) bolts on 6-speed equipped vehicles.

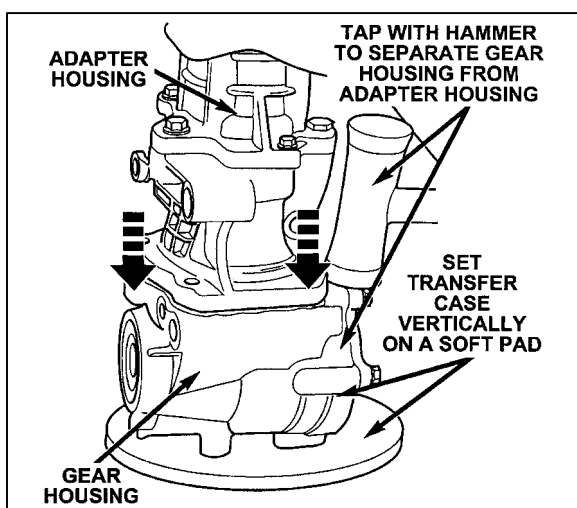

17. Position the transfer case vertically on a soft pad and separate the gear housing from the adapter housing by tapping the gear housing with a plastic hammer.

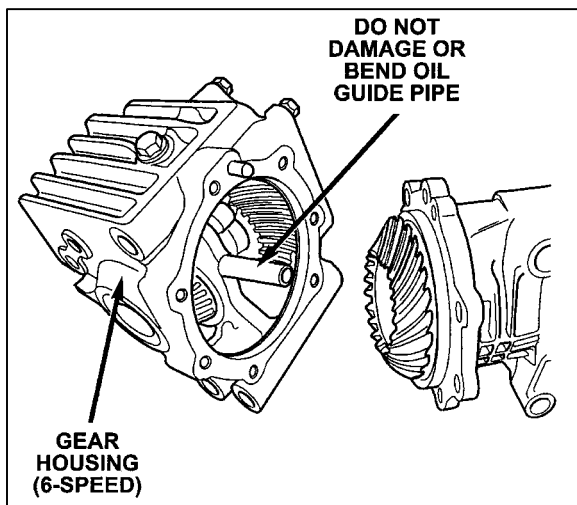

CAUTION

DO NOT bend or damage the oil guide pipe when separating the housings on 6-speed equipped vehicles.

Continued

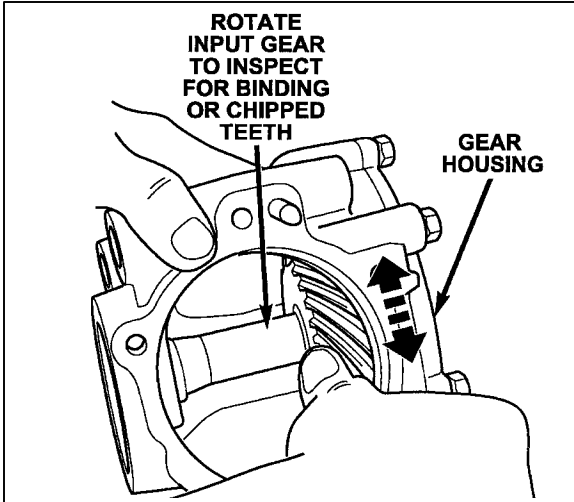

18. While holding the gear housing, rotate the input gear while inspecting for binding or chipped gear teeth.

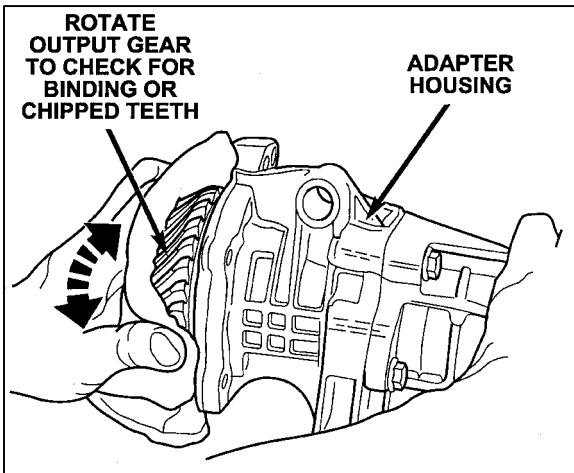

19. While holding the adapter housing, rotate the output gear, inspecting for binding or chipped gear teeth.

20. If either the input gear or output gear do not rotate smoothly or appear to be damaged, you must replace the transfer case with a new assembly. Proceed with **Section C. – Installing Transfer Case**. Reassemble the original transfer case and hold for possible warranty parts return (30 days past paid, end-of-month statement date).

Transfer case replacement requires prior approval from Tech Line. Refer to the PARTS INFORMATION section of this bulletin for details regarding ordering a new transfer case.

If the input gear and output gear rotate smoothly and have no apparent damage, proceed with **Section B. – Re-sealing the Transfer Case**.



Continued

B. Re-sealing Transfer Case

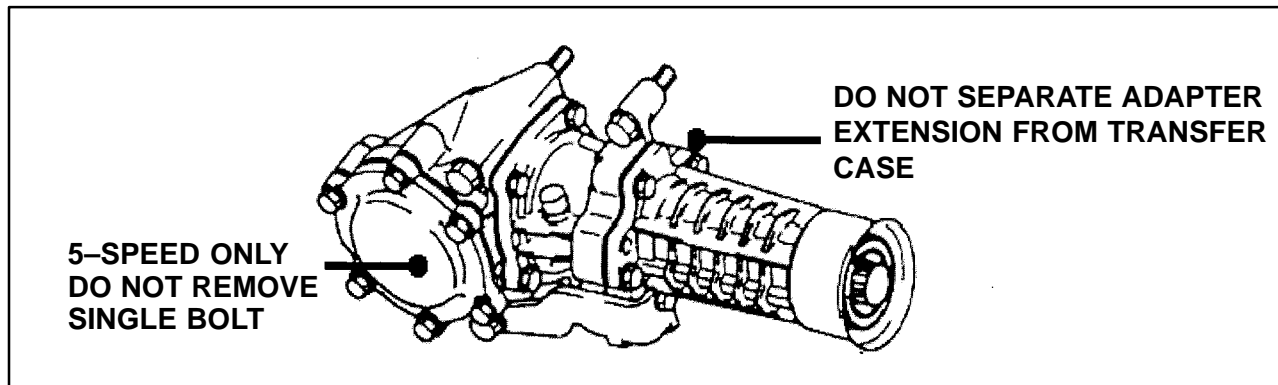

⚠ CAUTION

During disassembly of the transfer case, **DO NOT** separate the transfer case at the area indicated in the above illustration. On 5-speed transfer cases, **DO NOT** remove the single bolt in the center of the transfer case cover.

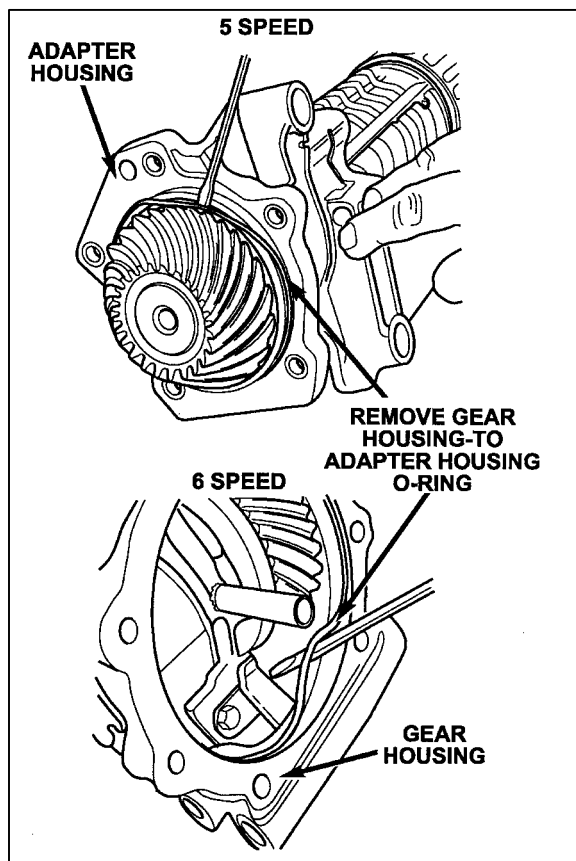

1. Remove the gear housing-to-adapter housing O-ring.

⚠ CAUTION

DO NOT damage the O-ring seat.

NOTE:

The O-ring is located on the adapter housing for 5-speed equipped vehicles and in the gear housing for 6-speed equipped vehicles.

2. Clean the adapter housing flange and O-ring seat (5-speed).
3. Clean the gear housing flange and O-ring seat (6-speed).

Continued

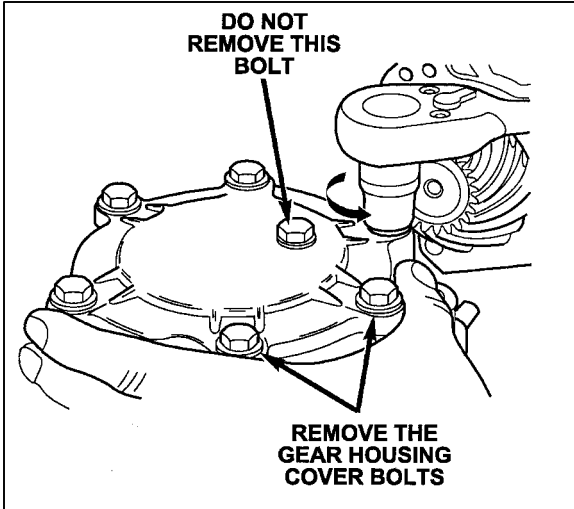

4. Remove the six bolts that secure the gear housing cover to the gear housing.

⚠ CAUTION

On 5-speed vehicles, do NOT remove the bolt in the center of the cover.

5. Place the gear housing on the work surface with the cover facing upward.
6. While holding the gear housing, tap one of the cover bolt bosses until the cover has turned sufficiently.
7. Set the gear housing on the work surface with the cover on the side. While holding the gear housing with your thumb in the input gear shaft cavity, tap the gear housing cover with a plastic hammer until it is separated from the housing. DO NOT damage the seal.

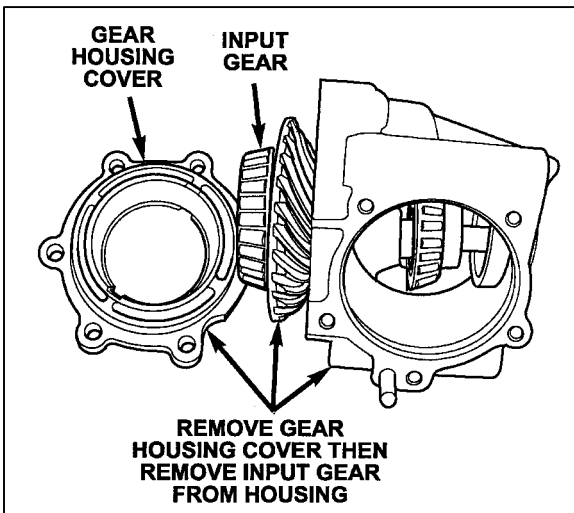

8. Remove the input gear from the gear housing.

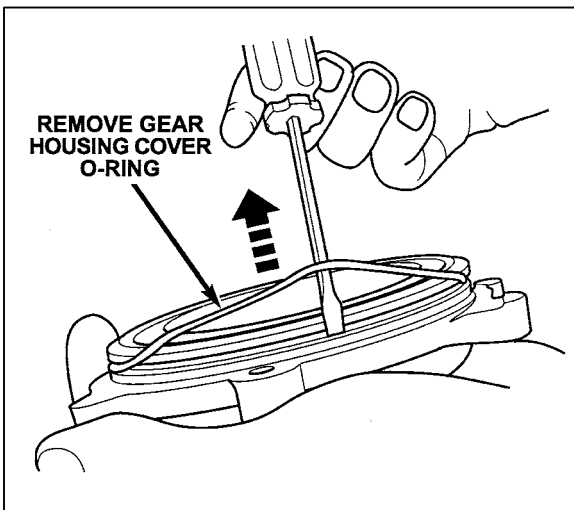

9. Remove the O-ring from the gear housing cover.

NOTE:

Some early-production 5-speed transfer cases do NOT have a cover O-ring.

10. Clean the gear housing cover flange and the cover O-ring groove and surface.
11. Remove any sealant from the gear housing and cover bolt holes.

Continued

12. Using a brass drift or a socket extension and a plastic hammer, remove the input shaft seal from the gear housing.
13. Set the adapter housing/extension housing assembly on the work surface with the output shaft facing upward.

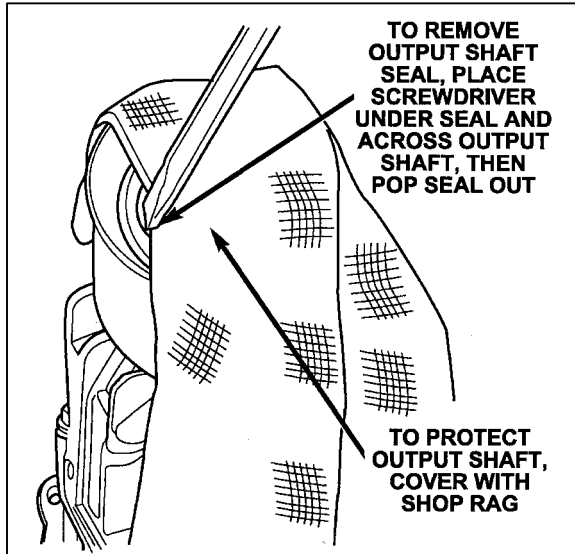

14. Carefully remove the output shaft seal. To remove the seal, place a flat blade screwdriver under the seal with the screwdriver shaft resting on the extension housing cuff. Remove the seal by quickly hitting the screwdriver handle and popping the seal from its seat.

NOTE: Protect the end of the output shaft by placing a shop rag over it prior to the seal removal.

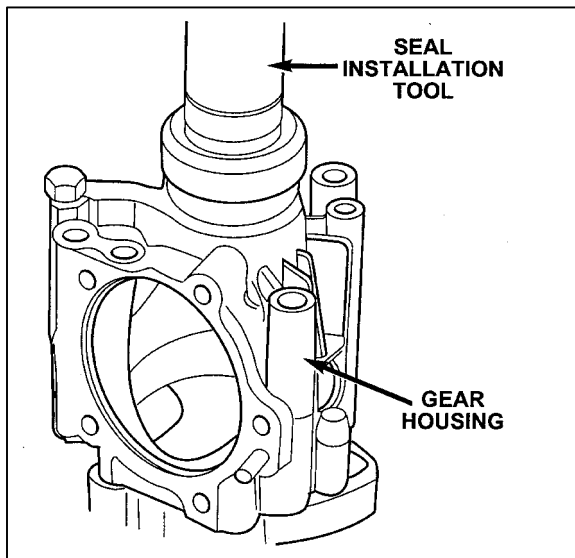

15. Place the new input shaft seal from the kit (Pos. D, oil seal) into the seal seat on the input gear housing.
 - a. For 5-speed transfer cases: Use a flat seal installation tool to press the seal into the housing with a lever press until the seal is flush with the housing surface.

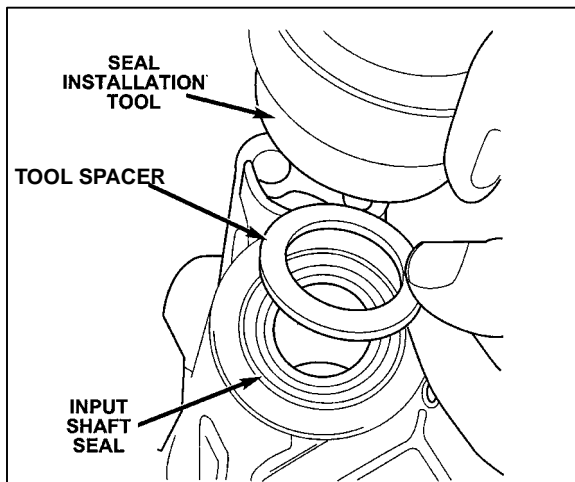

Remove the seal installation tool and place the supplied 2 mm spacer from the kit (Pos. D, Distance washer) on top of the input shaft seal. Place the tool on top of the spacer and press the seal further into the housing with the lever press until the spacer is flush with the housing surface. Remove the tool and spacer.

Continued

- b. For 6-speed transfer cases: Use a 36mm socket to press the seal into the housing with a lever press until the seal contacts the seat.

16. Lubricate the input shaft seal lip with a small amount of Mitsubishi White Lithium Grease (A999ZC1X05).

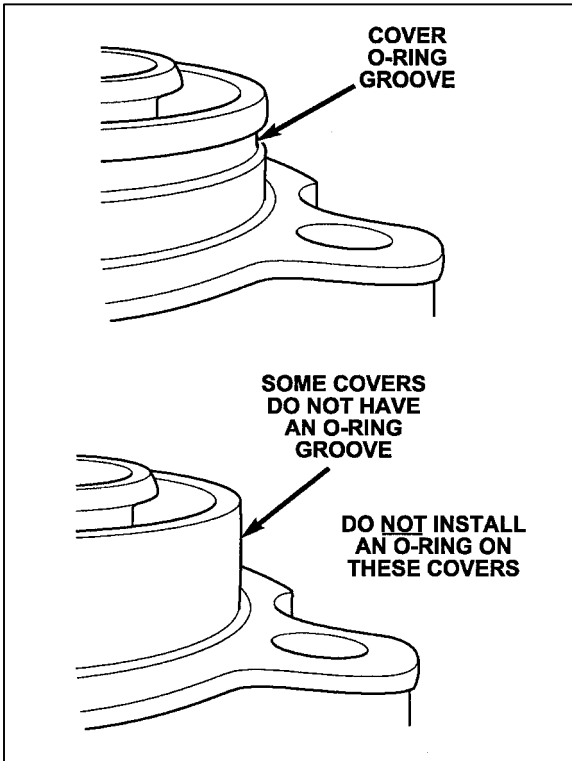

17. Lubricate the gear housing cover O-ring from the sealing kit (Pos. A, O-Ring) with Mitsubishi 75W-90/GL-5 Diamond Gear Lube (A991ZC2X01), then install the O-ring into the groove on the gear housing cover. DO NOT twist the O-ring.

NOTE:

Some early production 5-speed transfer cases did NOT have a cover O-ring. However, some of these covers do have an O-ring groove. A new cover O-ring MUST be installed if the cover has an O-ring groove. If the cover does NOT have an O-ring groove, DO NOT install a cover O-ring.

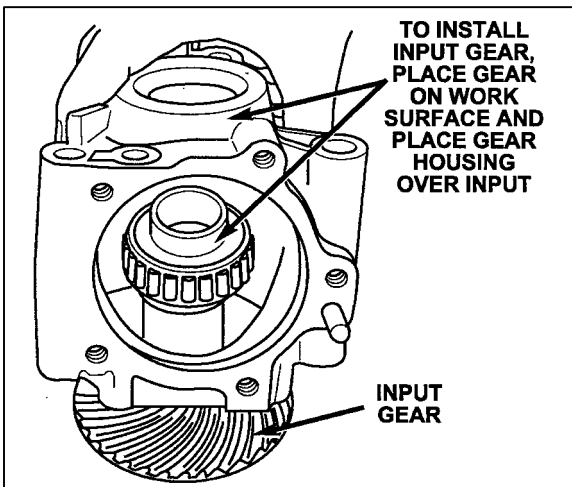

18. Install the input gear into the gear housing by placing the input gear assembly on the work surface with the shaft facing upward. Place the gear housing over the shaft. Make sure that the shaft slides easily into the input shaft seal and that the seal lip is not twisted.

Continued

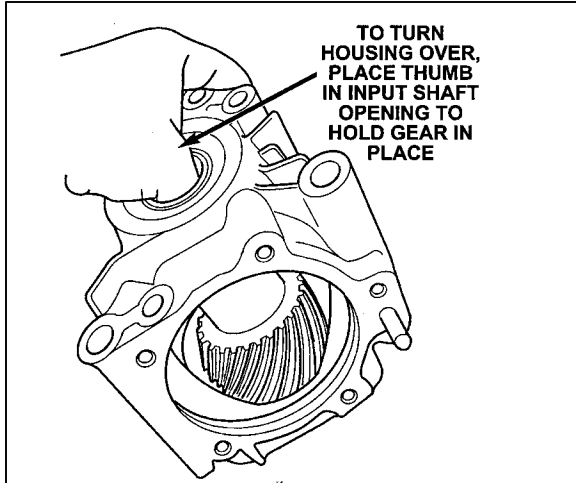

19. Place your thumb into the input shaft opening to hold the gear in position and then turn the gear housing over.

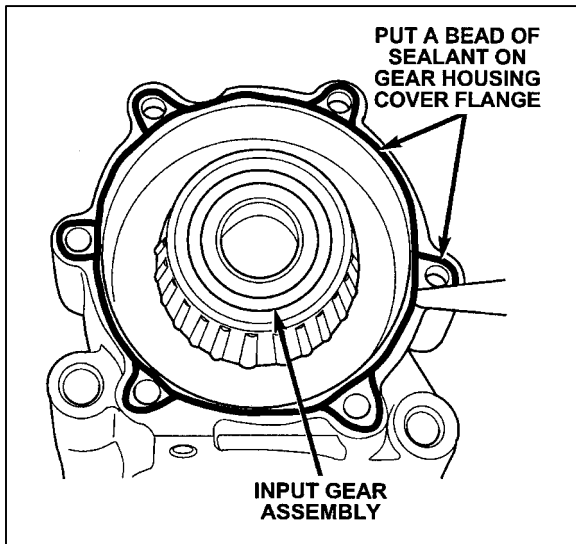

20. Run a bead of sealant (Mitsubishi Transmission Gasket Sealant A990ZC1X02) on the gear housing cover flange.

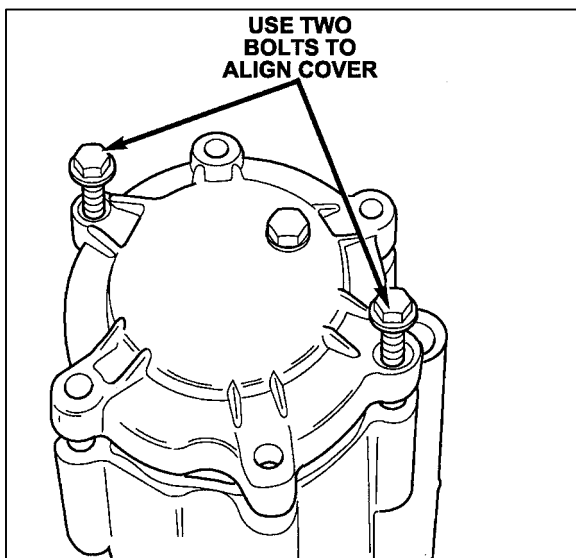

21. Carefully install the gear housing cover onto the gear housing. Position the cover by loosely installing two of the cover bolts. Seat the cover by tapping it with a plastic hammer or by using a press.
22. Remove the two bolts used to position the cover.
23. Apply Mitsubishi Threadlock (A990ZC1X05) to the threads of all cover bolts. Install the bolts and tighten each to 220 in-lbs (25Nm).

Continued

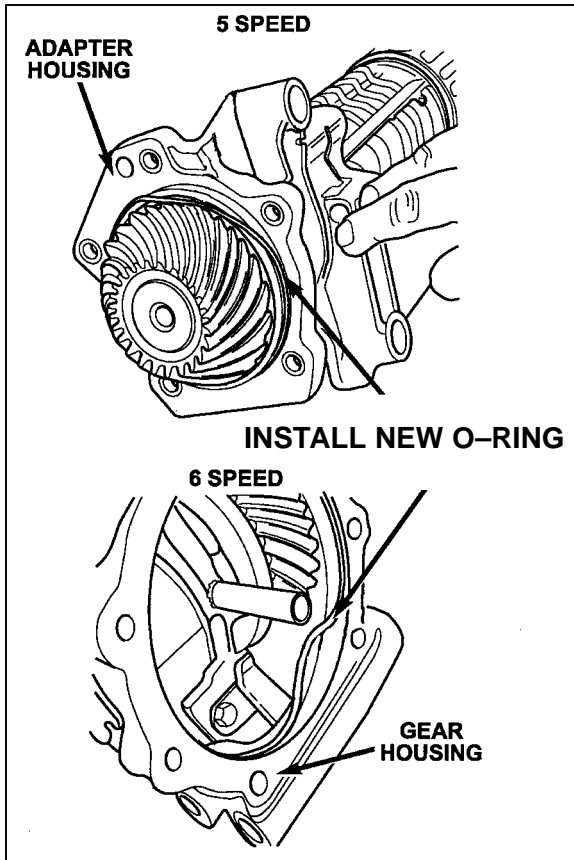

24. Lubricate gear housing-to-adapter housing O-ring (Pos. B, O-Ring) in the kit, with Mitsubishi 75W-90/GL-5 Diamond Gear Lube (A991ZC2X01). Install the O-ring onto the adapter housing (5-speed) or into the gear housing (6-speed). Make sure that the O-ring is not twisted.

NOTE:

There are two different gear housing-to-adapter housing O-rings contained in the repair kit. Make sure that the correct O-ring is used for the vehicle being serviced. The Pos. B O-ring for the 5-speed vehicle is the smaller diameter, with the O-ring for the 6-speed being the larger diameter.

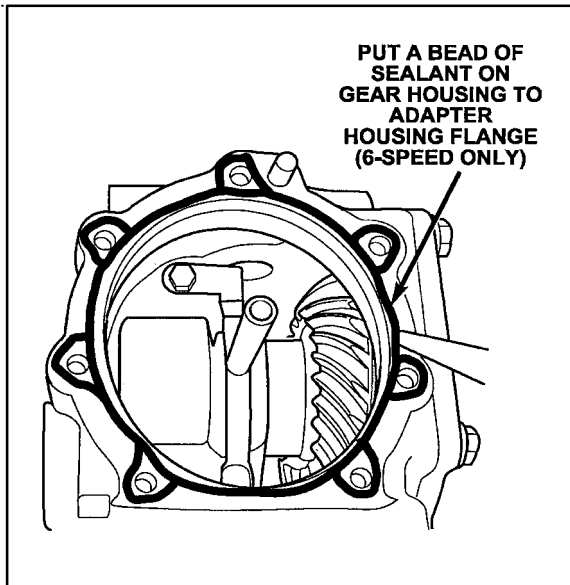

25. FOR 6-SPEED TRANSFER CASES ONLY: Put a bead of sealant (Mitsubishi Transmission Gasket Sealant A990ZC1X02) on the gear housing flange.

NOTE:

Do NOT use sealant on the 5-speed gear housing-to-adapter housing joint.

26. Stand the adapter housing assembly vertically on the work surface and then install the gear housing assembly onto the adapter housing. Make sure the dowel pins are properly aligned. Seat the gear housing by lightly tapping it with a plastic hammer.

Continued

27. Apply Mitsubishi Threadlock (A990ZC1X05) to the threads of the adapter housing-to-gear housing bolts, and then install the bolts and tighten to 220 in-lbs (25 Nm).

NOTE:

For 6-speed transfer cases, the bolts are not all the same length. Make sure that the one longer bolt is used in the position with the raised boss.

28. With the output shaft facing upward, place the transfer case on the work surface.

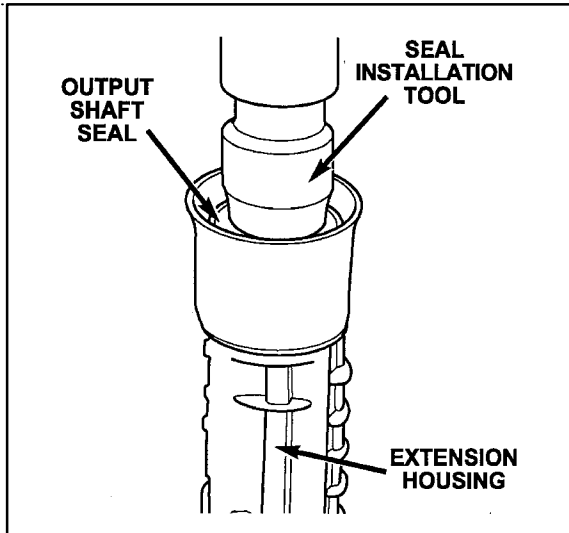

29. Place the supplied output shaft seal (Pos. E, Oil seal) from the kit into the extension housing seat.

30. Using a 36mm socket as a seal installation tool, press the output shaft seal into the housing with a lever press until the new seal contacts the seal seat.

31. Install a new aluminum gasket onto the drain plug. Install the drain plug into the transfer case and tighten the plug to 300 in-lbs (35 Nm). Two of these aluminum gaskets are supplied in the kit, and are marked Pos. G & H. The other gasket is for the transfer filler plug, which will be used in the next step.

32. Install a new aluminum gasket onto the filler plug. Install the filler plug into the transfer case and tighten the plug to 300 in-lbs (35 Nm).

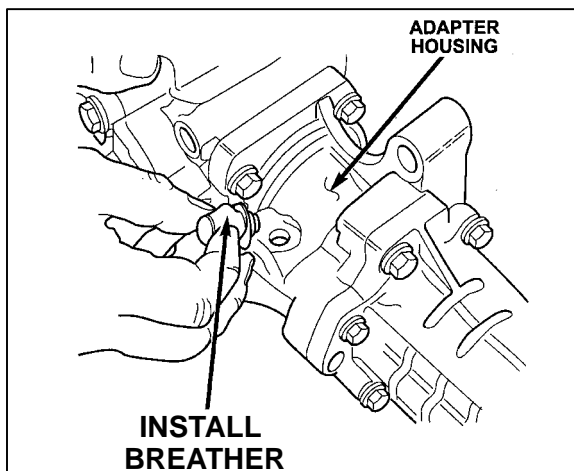

33. Clean the transfer case breather and seat, apply Mitsubishi Weatherstrip Adhesive (A990ZC1X03) around the breather hole and then install the breather.

34. The transfer case is now ready for installation into the vehicle. Proceed with **Section C – Installing Transfer Case.**

Continued



C. Installing Transfer Case

NOTE: If you are installing a NEW transfer case, tighten the drain plug and filler plug to 300 in-lbs (35 Nm).

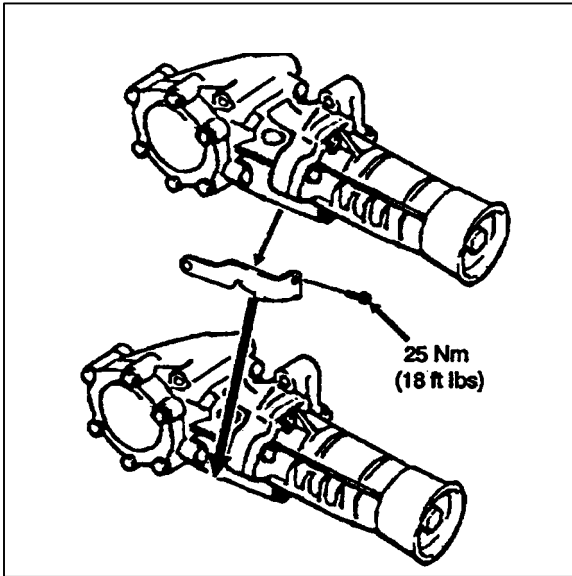

1. **FOR 5-SPEED EQUIPPED VEHICLES:**
Transfer the extension housing support bracket from the old transfer case to the new transfer case.

2. Coat the output shaft seal with a small amount of 75W-90/GL-5 gear lube.

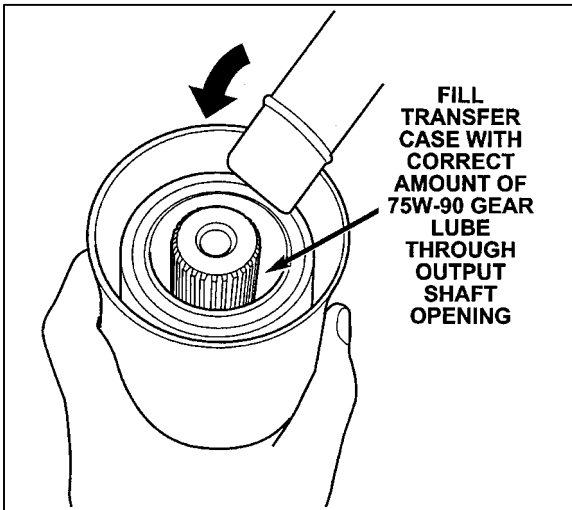

3. Fill the transfer case through the output shaft opening with Mitsubishi 75W-90/GL-5 Diamond Gear Lube (A991ZC2X01).

NOTE:

Transfer Case Gear Lube quantities:

5-speed transfer cases require 9.25 oz (270cc)

6-speed transfer cases require 20.25 oz. (600cc)

⚠ CAUTION

Be sure to use the correct amount of gear lube in each transfer case. Overfilling the transfer case can cause extensive powertrain damage.

4. Coat the transfer case input shaft and output shaft splines with Mitsubishi White Lithium Grease (A999ZC1X05).

5. Apply Mitsubishi White Lithium Grease to the transaxle output shaft and the driveshaft splines.

Continued

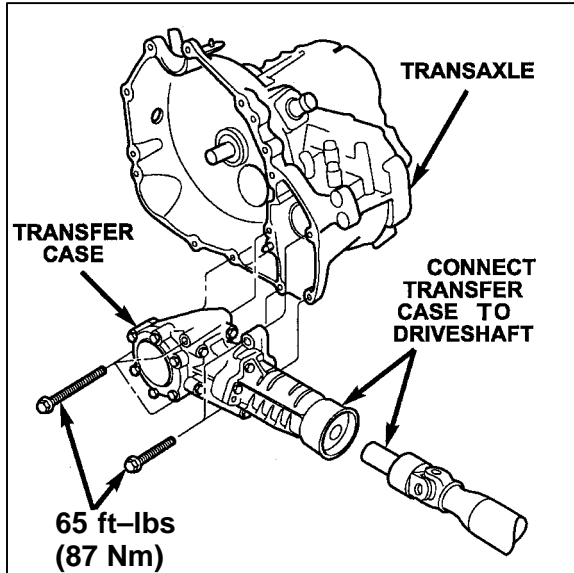

6. Insert the driveshaft into the transfer case and then mount the transfer case onto the transaxle.
7. Install the transfer case mounting bolts and tighten the mounting bolts to 65 ft-lbs (87 Nm). Remove the temporary driveshaft support.

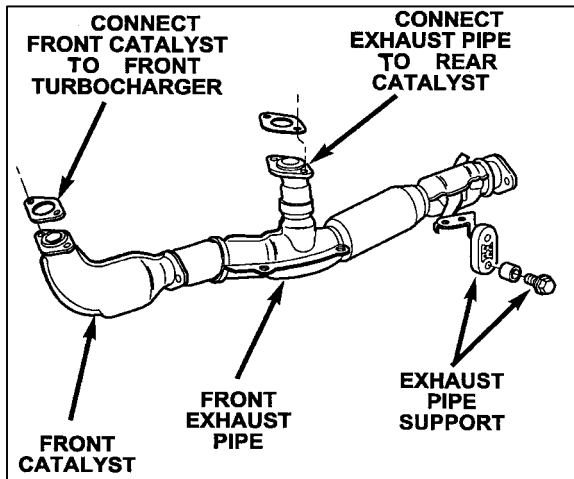

8. Using new exhaust gaskets and nuts, reconnect the front exhaust pipe to the front turbocharger outlet and the rear catalytic converter (Figure 26). Tighten the exhaust nuts to 37 ft-lbs (50 Nm).
9. Connect the front exhaust pipe support.
10. The repair is now completed. Lower the vehicle, test drive to make sure the powertrain operates properly and that there are no leaks. Return the vehicle to the customer when you have verified the repair is completed satisfactorily.

Continued

PARTS INFORMATION

Use the genuine Mitsubishi Parts listed below.

Description	Part Number	Allowed Quantity	Amount Claimed
Repair Kit (Transfer Case Re-sealing Kit)	MN156006	1	Dealer Net
Exhaust Gasket (rear – 6-speed only)	MB687015	1	Dealer Net
Exhaust Gasket (All w/5-speed, front only for 6-speed)	MB687002	1 or 2	Dealer Net
Self-locking nuts (exhaust)	MB059359	4	Dealer Net
Mitsubishi Gear Lube	A991ZC2X01	2 Pints	\$ 5.00

These transfer case assemblies have a manual allocation code because replacement requires prior approval from Tech Line. The technician must first contact Tech Line and explain the repair condition. If replacement is approved, Tech Line will assign a case number. Then, you must contact your facing PDC to order the transfer case and provide them that case number. The case number will be entered into MAPS as the “dealer location” for the order to be released.

Transfer Case Assembly, 5-speed, small shaft (if required)	MN156477	1	Dealer Net
Transfer Case Assembly, 5-speed, large shaft (if required)	MN156478	1	Dealer Net
Transfer Case Assembly, 6-speed (if required)	MN156479	1	Dealer Net

Additional Supplies

The following Genuine Mitsubishi supplies will be required to complete the items in this campaign.

Description	Part Number	Maximum Amount Claimed
Mitsubishi Weatherstrip Adhesive	A990ZC1X03	\$ 2.30
Mitsubishi White Lithium Grease	A999ZC1X05	\$ 1.90
Mitsubishi Transmission Gasket Sealant	A990ZC1X02	\$ 1.45
Mitsubishi Threadlock	A990ZC1X05	\$ 2.30

WARRANTY INFORMATION

Claims for this campaign must be entered as Recall Type “C” claims on your Diamond Network Service Menu. Sample claim screens are shown on the next pages.

Transfer Case Oil Change (Drain & Refill)

Campaign Labor Operation: C0203NXX Time Allowance: 0.4 hrs.

Transfer Case Repair (Installation of Seal Kit) (Includes Oil Refill)

Campaign Labor Operation: C0203NXX Time Allowance: 2.0 hrs.

Transfer Case Replacement (Includes Oil Refill)

Campaign Labor Operation: C0203NXX Time Allowance: 1.1 hrs.

SERVICE CAMPAIGN CLAIM SAMPLE - LABOR OPERATION = C0203NXX

ADVANCED DIAMOND NET SCREENS FOR RECALL CLAIMS
(ALSO APPLIES TO WEB BASED CLAIMS)

SERVICE MENU - SELECT RECALL CLAIM (C)

ENTER THIS CLAIM AS RECALL CLAIM TYPE 'C' ONLY.

RECALL CAMPAIGN CUSTOMER / REPAIR INFO SCREEN

FILL IN ALL OF THE REQUIRED OWNER INFORMATION ITEMS INCLUDING PHONE NUMBER.

Be sure the vehicle is actually involved in this campaign. Check the Super Screen to be sure.

If the transfer case is replaced, you must enter the Tech Line Case # in the sublet information box. You must obtain the techline case # prior to the replacement of the transfer case.

Web dealers should enter this information in the spec value field.

RECALL CAMPAIGN CLAIM PARTS AND LABOR DETAIL INFO SCREEN:

USE C0203NXX FOR THE LABOR OPERATION :

Recall Claim (C) Entry - Advanced Diamond Network System v1.03
[] [] [X]



Vehicle



Service



Parts



Comm



Reports

Interface

Profile

Financial

Help

Exit

Claim Number: Claim Type:

Repeat: Vehicle Repair PWA: Reasons Mileage

Repair Date: VIN:

Customer / Repair Info
→ Parts & Labor Detail Info ←

INSPECT AND INSTALL THE PROTECTOR FOR THE FRONT HARNESS

Verify the vehicle is actually involved in this campaign by checking the Superscreen.

Line	Part Number	Qty	Cost	Sub	Operation	Qty	Lbr Hours	Amount	Delete
A	<input type="text"/>	<input type="text"/>	<input type="text"/>		C0203NXX	1	??	<input type="text"/>	<input type="text"/>

Enter only the applicable part numbers related to the actual repair performed from the list on page 16 of this TSB.

The parts claimed must match the repair performed.

Enter C0203NXX

Enter only one of the applicable labor times listed below:

Transfer Case Oil Change ONLY = .4 hrs
or
Transfer Case Repair (Seal Kit) and Oil Change = 2.0 hrs
or
Transfer Case Replacement = 1.1 hrs

Detail Lines Total Parts

Page

AFFECTED VEHICLES
MODEL: 1991-1999 3000GT VR-4



6400 KATELLA AVENUE
CYPRESS, CALIFORNIA 90630-5208
(888) MITSU2002

Date: December, 2002

RE: IMPORTANT SAFETY RECALL NOTIFICATION

Dear Mitsubishi Owner,

This notice is sent to you in accordance with the requirements of the National Traffic and Motor Vehicle Safety Act. You may have received a prior notice to have the transfer case oil in your vehicle inspected. Parts are now available for transfer case seal replacement.

What is the safety issue? Mitsubishi Motor Sales of America, Inc. has determined that a defect which affects vehicle safety exists in certain 1991 through 1999 Mitsubishi 3000GT VR-4 vehicles. There is a possibility that a leak in the transfer case may cause bearing failure and subsequent lock-up of the wheels, which could result in a crash.

What Your Retailer Will Do: Your retailer will inspect the transfer case for leakage or damage and, if necessary, replace the seals and re-fill the transfer case to the proper level; or replace the transfer case if there is evidence of damage.

What You Should Do: Please contact your authorized Mitsubishi retailer immediately to schedule an appointment for the repair. There will be no charge for this repair.

How Long Will It Take? The repair to the transfer case will take approximately two hours to complete, but may take longer, depending upon your dealer's schedule.

Have you changed address or sold the vehicle? If you have changed your address or sold the vehicle, please fill out the enclosed postcard and mail it to us.

If you have already encountered the problems described above and have paid for the repair, you may send your original receipts and/or other adequate proof of payment to the following address for reimbursement:
Mitsubishi Motor Sales of America, Inc., Customer Connections Dept., P.O. Box 6400, Cypress, CA 90630-0064.

If you have any trouble getting your vehicle repaired promptly and at no charge, please inform us by calling:

Mitsubishi Customer Connections Department
(888) MITSU-2002 (888-648-7820)

Hours: Monday – Saturday 7 a.m. to 10 p.m. (Central Standard Time)

If after contacting Mitsubishi Customer Connections, you still have a problem having your vehicle repaired promptly and without charge, write to the Administrator, National Highway Traffic Safety Administration, 400 Seventh Street SW, Washington, D.C. 20590, or call the Auto Safety Hotline toll-free (888) 327-4236.

Mitsubishi is committed to making your safety our first concern and we sincerely regret any inconvenience to you caused by this recall.

Sincerely,

SR-02-003
C0203NXX

Richard Donnelson
Director, Service and Product Support

Dealer Check Form

1. Specification

(1) Vehicle record

DEALER CODE :

VIN :

Mileage :	miles/km
-----------	----------

T/F No. :

5- speed

6- speed

Repair and maintenance records if existed		
(1) Year	Month	miles/km
(Contents)		
(2) Year	Month	miles/km
(Contents)		

(2) Check for potential oil leakages at the position A - H

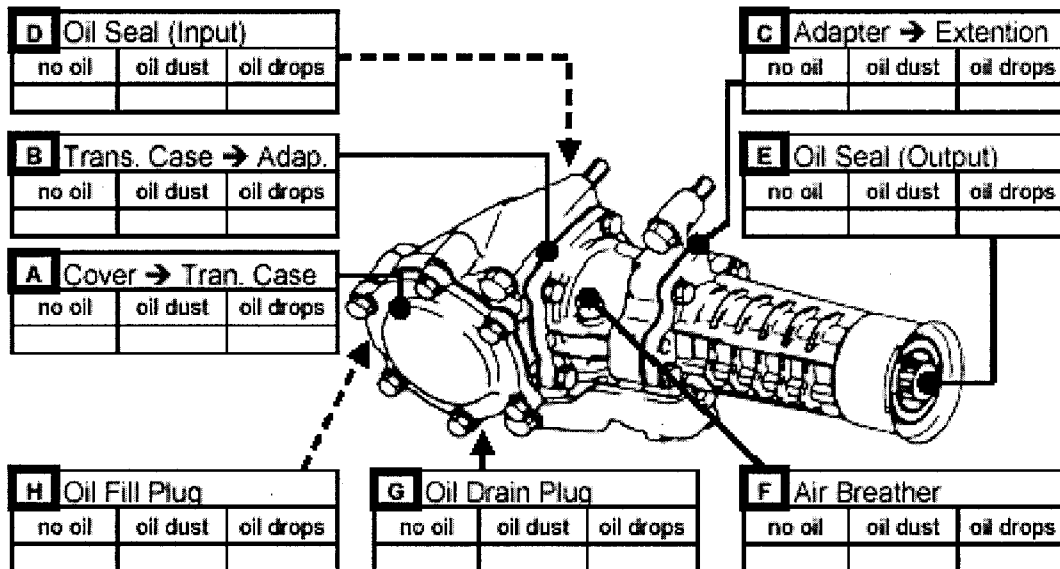

<The following boxes are required to fill only in case of disassembling.>

Operation 1-(4) Notes the amount of drained oil.

T/F oil amount :	cc
------------------	----

Operation 5 check either for the reason replacement of T/F.

<input type="checkbox"/>	Broken Bearing
<input type="checkbox"/>	Chipped Teeth